



AIR PREPARATION SYSTEM P3X LITE SERIES

G1/2 & G3/4 Body ported

Table of Contents

The System	3
Nano Mist.....	4
Popular combinations	5
Filters	6 – 7
Coalescing filters	8 – 9
Adsorber filters	10 – 11
Regulators	12 – 13
Filter regulators	14 – 15
Lubricators	16 – 17
Combined Soft Start Dump Valves	20 – 21
Modular slide valve	22
Modular manifold	22
Solenoid Coils	23
Accessories	24



WARNING – USER RESPONSIBILITY

FAILURE OR IMPROPER SELECTION OR IMPROPER USE OF THE PRODUCTS DESCRIBED HEREIN OR RELATED ITEMS CAN CAUSE DEATH, PERSONAL INJURY AND PROPERTY DAMAGE.

- This document and other information from Parker-Hannifin Corporation, its subsidiaries and authorized distributors provide product or system options for further investigation by users having technical expertise.
- The user, through its own analysis and testing, is solely responsible for making the final selection of the system and components and assuring that all performance, endurance, maintenance, safety and warning requirements of the application are met. The user must analyze all aspects of the application, follow applicable industry standards, and follow the information concerning the product in the current product catalog and in any other materials provided from Parker or its subsidiaries or authorized distributors.
- To the extent that Parker or its subsidiaries or authorized distributors provide component or system options based upon data or specifications provided by the user, the user is responsible for determining that such data and specifications are suitable and sufficient for all applications and reasonably foreseeable uses of the components or systems.

SALE CONDITIONS

The items described in this document are available for sale by Parker Hannifin Corporation, its subsidiaries or its authorized distributors. Any sale contract entered into by Parker will be governed by the provisions stated in Parker's standard terms and conditions of sale (copy available upon request).

The System

The P3X system allows units to be connected together, without the use of pipe connectors, saving space; providing constant mounting centres; whilst maintaining a modern aesthetically pleasing appearance.

The P3X Filters are specially designed to efficiently filter out rust, dirt, moisture and other impurities from compressed air lines. Operation is fully automatic with a minimum of pressure drop. Coalescing filters and adsorber filters for high purity air are also included in the P3X series.

The P3X Regulators are designed to provide quick response and accurate pressure regulation for the most demanding hi-flow industrial applications. The rolling diaphragm was designed for long trouble-free operation and will not rupture or tear under high cycle or other demanding applications.

The P3X mist lubricators are designed to provide lubrication for many general purpose applications in a pneumatic system.

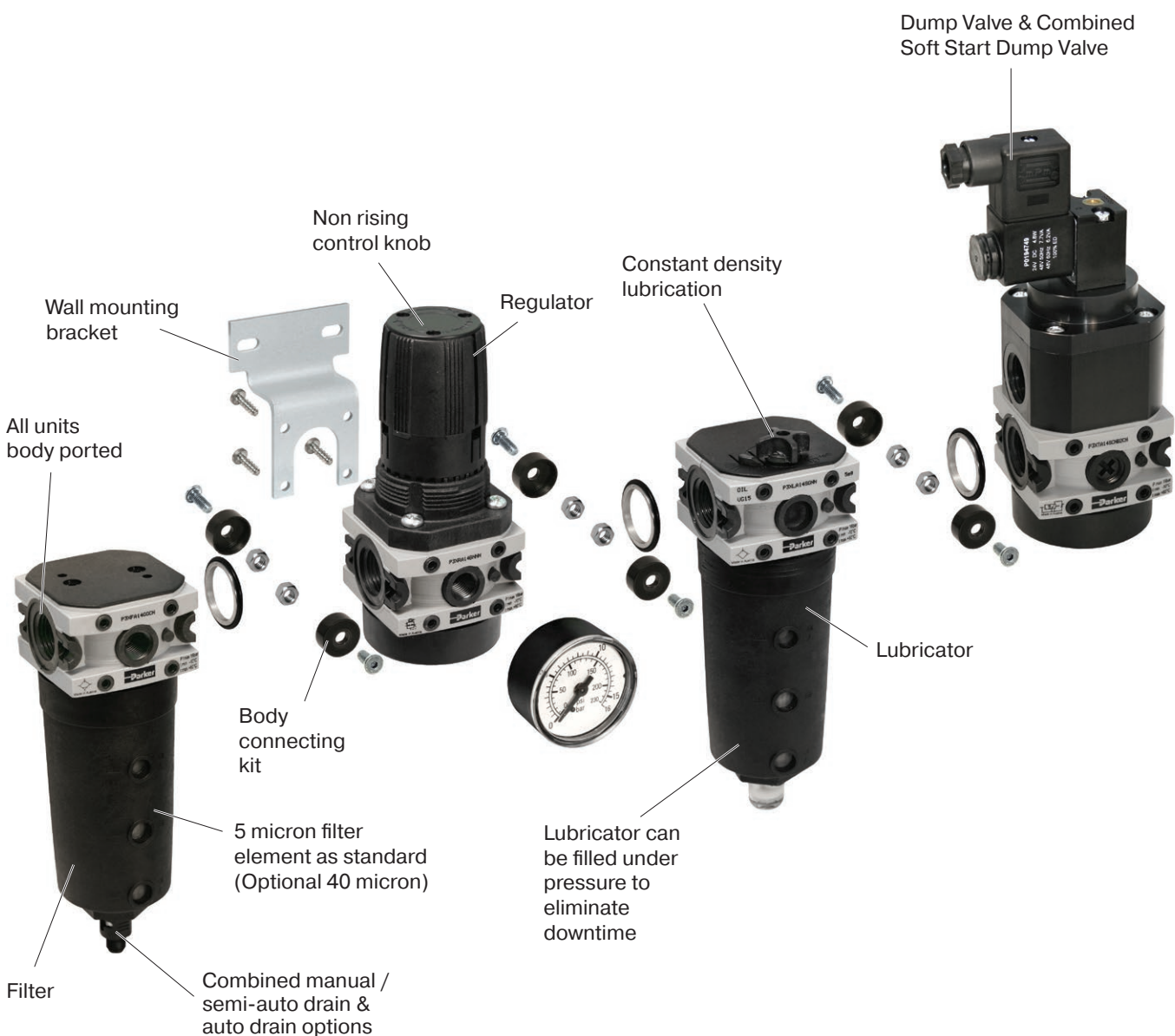

New Technology

The P3X Lite FRL system is constructed from ultra light weight technopolymers instead of the traditional aluminium or zinc die cast, this means that is up to 45% lighter than conventional units. This non-metal construction also means that the P3X Lite is corrosion free enabling it to be used in harsh industrial environments where anti freeze or aggressive synthetic oils are present.

The use of technopolymers in the design of P3X Lite has facilitated a universal body design, this has resulted in reducing the number of variants required to cover the full spectrum of applications. This can dramatically lower logistic costs and simplify stock holding for customers making the P3X Lite a very cost effective solution.



Nano Mist

New Nano Mist Technology, New Lubricator Concept. Self-Adjusting.

With conventional lubricators, only the oil volume per time unit can be adjusted. If the demand changes, the quantity dispensed still remains constant.

The P3X Lite lubricator concept sets new benchmarks here. For the first time, the oil volume is automatically adjusted to the flow rate. This ensures that there is neither too little nor too much oil in the system, which leads to clear economic and ecological advantages. In addition, with conventional systems, the distance between the lubricator and the equipment has to be less than 8 meters. With larger distances, the dispensed oil is deposited as a wall flow. The new lubricator principle of the P3X Lite allows for distances of up to 40 meters. This opens up new scope for the design of even more efficient production systems.

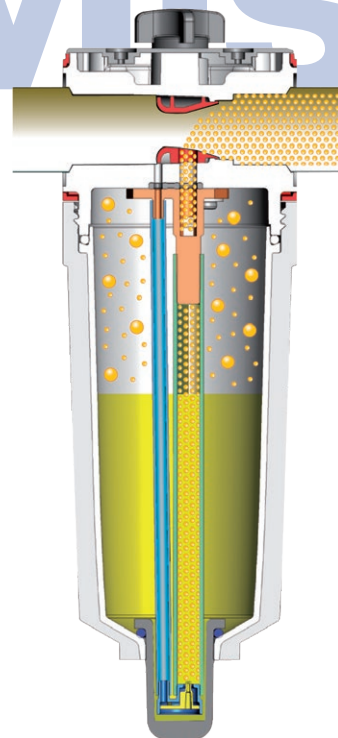

Popular Combinations

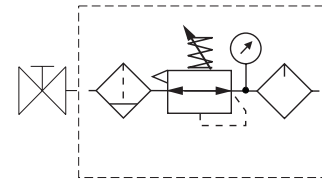

**Slide Valve + Filter/Regulator + Lubricator Combinations (50mg/m³)
 5 micron element, 8 bar Regulator + Gauge and Wall Mounting Brackets**

Port size	Combined Manual/Semi-Auto Drain	Flow dm ³ /s	Weight (g)	Auto Drain	Flow dm ³ /s	Weight (g)
G ¹ / ₂	P3XAA14GECNGPNW	76	1300	P3XAA14GEANGPNW	76	1300
G ³ / ₄	P3XAA16GECNGPNW	77	1300	P3XAA16GEANGPNW	77	1300

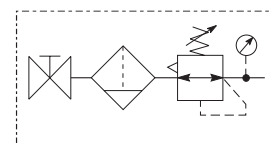

**Slide Valve + Filter/Regulator Combinations
 5 micron element, 8 bar Regulator + Gauge and Wall Mounting Brackets**

Port size	Combined Manual/Semi-Auto Drain	Flow dm ³ /s	Weight (g)	Auto Drain	Flow dm ³ /s	Weight (g)
G ¹ / ₂	P3XAN14GECNGW	105	950	P3XAN14GEANGW	105	950
G ³ / ₄	P3XAN16GECNGW	106	950	P3XAN16GEANGW	106	950

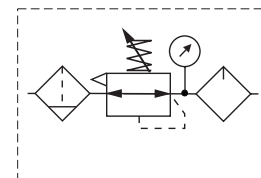

**Filter/Regulator + Lubricator Combinations (50mg/m³)
 5 micron element, 8 bar Regulator + Gauge and Wall Mounting Brackets**

Port size	Combined Manual/Semi-Auto Drain	Flow dm ³ /s	Weight (g)	Auto Drain	Flow dm ³ /s	Weight (g)
G ¹ / ₂	P3XCA14GECNGPNW	76	1000	P3XCA14GEANGPNW	76	1000
G ³ / ₄	P3XCA16GECNGPNW	77	1000	P3XCA16GEANGPNW	77	1000

Options:

P 3 X		1		GE				PN	W
Filter/Reg + Lubricator	CA	BSPP (G)	1	Combined Manual/Semi Auto Drain	C	0 - 8 bar with gauge	G		
Slide valve + Filter/Reg	AN	NPT *		Auto Drain	A	0 - 16 bar with gauge	J		
Slide valve + Filter/Reg + Lubricator	AA								
* 1/2" NPT see Accessories		1/2	4	Non rise - Standard	N	(50mg/m ³)	PN	Add only for options with lubricator	
		3/4	6	Tamperproof - Lockable	A				

Particulate Filters



Symbols

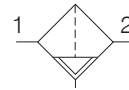

Manual / Semi auto drain

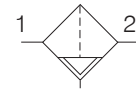

Auto drain

- Integral 1/2 or 3/4" ports
- 2 stage filtration
- High efficiency 5µ particulate element as standard
- Excellent water removal efficiency
- Low temperature -40°C with combined manual/semi - auto drain as standard

Options:

P3XFA	1	□	□	□	G	□	N																		
<table border="1" style="border-collapse: collapse;"> <tr> <td>BSP (G)</td> <td style="text-align: center;">1</td> </tr> <tr> <td>NPT *</td> <td></td> </tr> </table>	BSP (G)	1	NPT *		<table border="1" style="border-collapse: collapse;"> <tr> <td>1/2</td> <td style="text-align: center;">4</td> </tr> <tr> <td>3/4</td> <td style="text-align: center;">6</td> </tr> </table>	1/2	4	3/4	6	<table border="1" style="border-collapse: collapse;"> <tr> <td>5 Micron Element Standard</td> <td style="text-align: center;">E</td> </tr> <tr> <td>40 Micron Element Optional</td> <td style="text-align: center;">G</td> </tr> <tr> <td>1 Micron Dust Filter</td> <td style="text-align: center;">2</td> </tr> </table>		5 Micron Element Standard	E	40 Micron Element Optional	G	1 Micron Dust Filter	2	<table border="1" style="border-collapse: collapse;"> <tr> <td>Combined Manual/Semi Auto Drain</td> <td style="text-align: center;">C</td> </tr> <tr> <td>Auto Drain</td> <td style="text-align: center;">A</td> </tr> </table>		Combined Manual/Semi Auto Drain	C	Auto Drain	A		
BSP (G)	1																								
NPT *																									
1/2	4																								
3/4	6																								
5 Micron Element Standard	E																								
40 Micron Element Optional	G																								
1 Micron Dust Filter	2																								
Combined Manual/Semi Auto Drain	C																								
Auto Drain	A																								
* 1/2" NPT see Accessories																									

Port size	Description	Order Code	Flow dm ³ /s *	Max bar	Min temp °C	Max temp °C	Bowl capacity cm ³	Height mm	Width mm	Depth mm	Weight g
1/2	Combined manual/semi auto drain	P3XFA14EGCN	55	16	-40	60	60	192	62	62	320
1/2	Auto drain	P3XFA14EGAN	55	16	-10	60	60	192	62	62	320
3/4	Combined manual/semi auto drain	P3XFA16EGCN	57	16	-40	60	60	192	62	62	320
3/4	Auto drain	P3XFA16EGAN	57	16	-10	60	60	192	62	62	320

* flow with 6,3 bar inlet pressure and 0,5 pressure drop.

Technical Information

Fluid:	Compressed air	
Maximum inlet pressure:	16 bar	
Temperature range*:	-10 to +60°C	
Auto drain:	-40 to +60°C	
Combined drain:	-40 to +60°C	
Particle removal:	1, 5 & 40 micron	
Typical flow with 5µm element 6,3 bar inlet pressure and 0.5 bar pressure drop:	1/2"	55 dm ³ /s
Semi-auto drain: bowl pressure to close drain	0.8 bar	
Auto drain: bowl pressure to close drain	0.8 bar	
Operating range	0.8 to 16 bar	
manual override facility		
Bowl sump capacity:	60 cm ³	

* Air supply must be dry enough to avoid ice formation at temperatures below +2°C

Material Specification

Body:	High tech polymer
Sight glass:	Polypropylene
Body cover:	ABS
Element:	Sintered P.E.
Seals:	Nitrile NBR
Drains:	Manual / Semi-auto: Acetal
	Automatic: PA / Brass

Dimensions (mm)

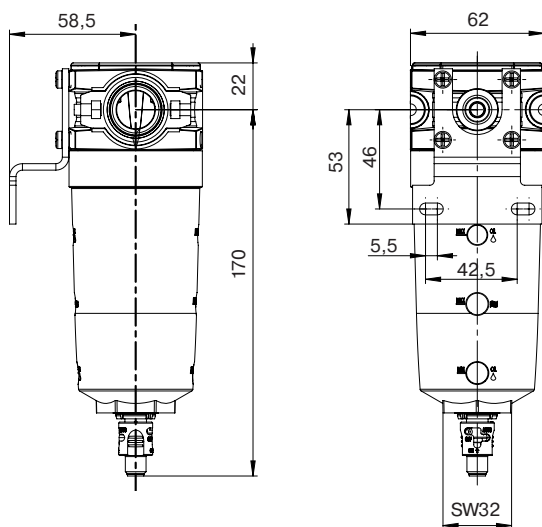

Service kits

Description	Order code
5 micron element kit	P3XKA00ESE
40 micron element kit	P3XKA00ESG
Bowl kit with combines manual/semi auto drain	P3XKA00BSC
Bowl kit with auto drain	P3XKA00BSA
1 micron element kit	P3XKA00ES9

Flow characteristics

(1/2) 5 Micron Filter

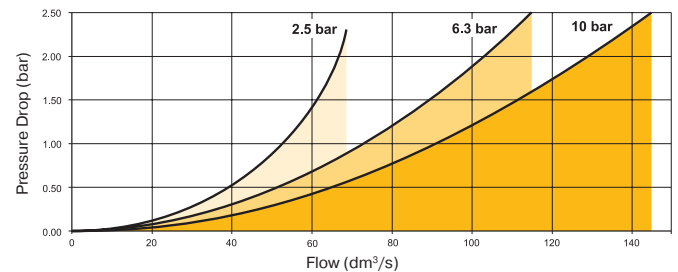

(3/4) 5 Micron Filter

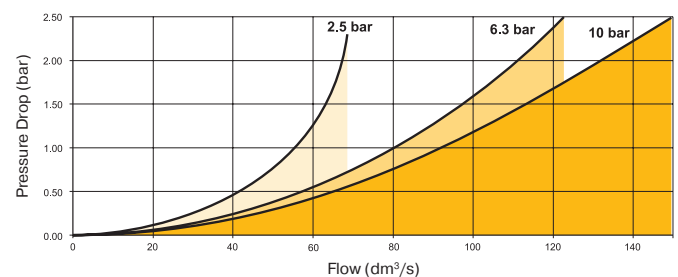

Coalescing Filters



- Integral 1/2 or 3/4 ports
- Removes liquid aerosols and sub micron particles
- Oil free air for critical applications, such as air gauging, pneumatic instrumentation and control

Note: To optimise the life of the coalescing element, it is advisable to install a P3XFA pre-filter with a 5 or 1 micron element upstream of the coalescing filter.

Options:

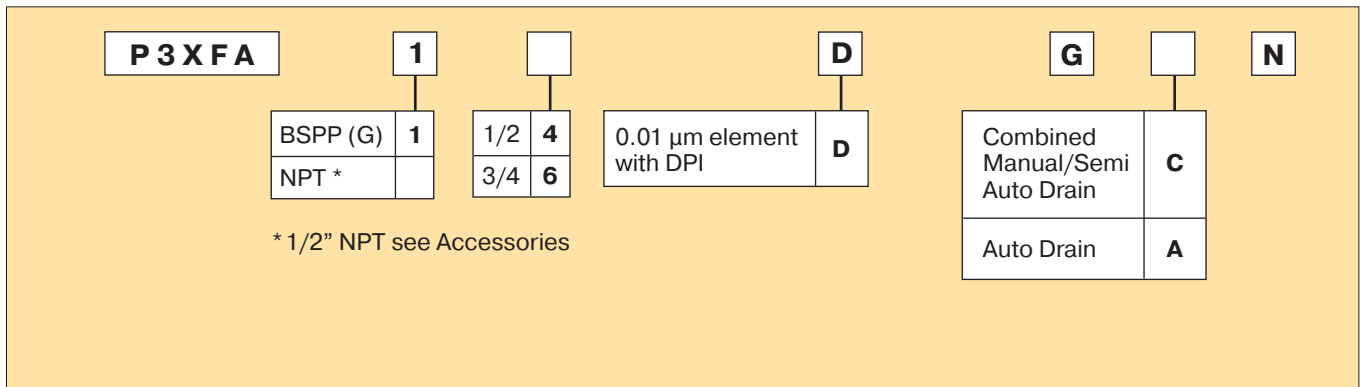

Port size	Description	Order Code	Flow dm ³ /s *	Max bar	Min temp °C	Max temp °C	Bowl capacity cm ³	Height mm	Width mm	Depth mm	Weight g
1/2	Coalescing Filter 0.01µm, Combined manual/semi auto drain	P3XFA14DGCN	24	16	-10	60	60	217	62	62	320
1/2	Coalescing Filter 0.01µm, auto drain	P3XFA14DGAN	24	16	-10	60	60	217	62	62	320
3/4	Coalescing Filter 0.01µm, Combined manual/semi auto drain	P3XFA16DGCN	24	16	-10	60	60	217	62	62	320
3/4	Coalescing Filter 0.01µm, auto drain	P3XFA16DGAN	24	16	-10	60	60	217	62	62	320

* flow with 6,3 bar inlet pressure and 0,2 pressure drop.

Technical Information

Fluid:	Compressed air
Maximum inlet pressure:	16 bar
Temperature range*:	-10 to +60°C
Media specifications:	
Coalescing efficiency	(0.3 to 0.6 micron particles): 99.97%
Max. oil carryover (PPM w/w):	0.008 mg/m ³
Typical flow element @ 6,3 bar inlet pressure and 0.2 bar pressure drop:	16 dm ³ /s
Manual / Semi-auto drain:	
Bowl pressure to close drain	0.8 bar
Auto drain:	
bowl pressure to close drain	0.8 bar
Operating range manual override facility	0.8 to 16 bar
Bowl sump capacity:	60 cm ³

* Air supply must be dry enough to avoid ice formation at temperatures below +2°C

Material Specification

Body:	High tech polymer
Sight glass:	Polypropylene
Filter cover:	ABS
Coalescing element:	Borosilicate & Nano fibres
Top & bottom end cap:	Glass filled nylon - Black
Support cylinders:	Grade 430 stainless steel
Support media:	Polypropylene
Anti re-entrainment barrier:	Polyester
Ensapulate:	Epoxy resin / Hardener
Seals:	Nitrile NBR
Drains:	Manual / Semi-auto: Acetal
	Automatic: PA / Brass

Differential pressure indicator materials:

Body:	Acetal
Internal parts:	Acetal
Spring:	Stainless steel
Seals:	Nitrile NBR
Screws:	Steel / zinc plated

Dimensions (mm)

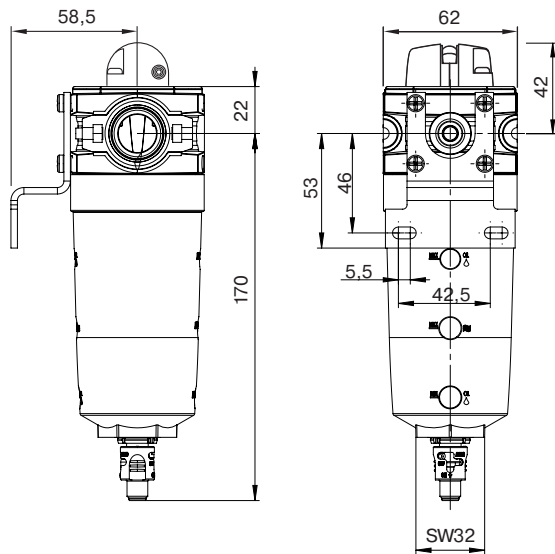

Service kits

Description	Order code
0.01 micron coalescing element kit	P3XKA00ESC
Bowl kit with combines manual/semi auto drain	P3XKA00BSC
Bowl kit with auto drain	P3XKA00BSA
Differential pressure indicator kit	P3XKA00RQ

Flow characteristics

(1/2) 0.01µm Coalescing Filter Saturated

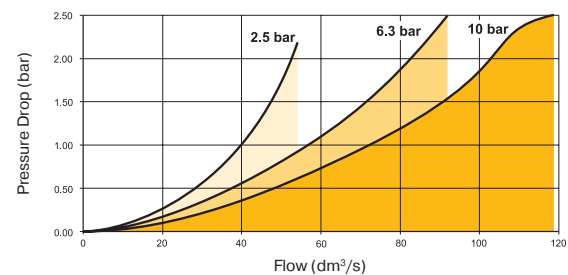

(3/4) 0.01µm Coalescing Filter Saturated

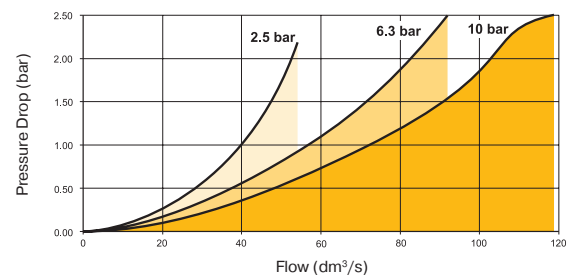

Adsorber Oil Vapour Filters



- Integral 1/2 or 3/4 ports
- Adsorber activated carbon element removes oil vapours and most hydrocarbons

Note: To optimise the life of the adsorber element, it is advisable to install a P3X pre filter 1 or 5 micron and a coalescer 0.01 µm filter upstream of the adsorber filter

Options:

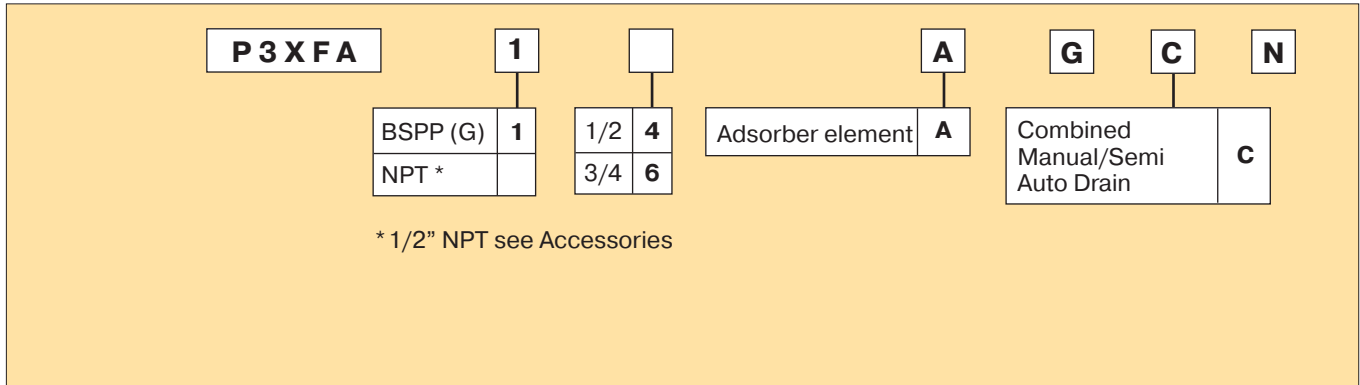

Port size	Description	Order Code	Flow dm ³ /s *	Max bar	Min temp °C	Max temp °C	Bowl capacity cm ³	Height mm	Width mm	Depth mm	Weight g
1/2	Adsorber Filter, Manual/Semi-auto drain	P3XFA14AGCN	18	16	-10	60	60	192	62	62	320
3/4	Adsorber Filter, Manual/Semi-auto drain	P3XFA16AGCN	18	16	-10	60	60	192	62	62	320

* flow with 6,3 bar inlet pressure and 0,2 pressure drop.

Technical Information

Fluid:	Compressed air	
Maximum inlet pressure:	16 bar	
Temperature range*:	-10° to +60°C	
Typical flow at 6,3 bar inlet pressure and 0.2 bar pressure drop:	Adsorber	18 dm ³ /s
Manual / Semi-auto drain to close connection:	1/8" connection	0.8 bar

* Air supply must be dry enough to avoid ice formation at temperatures below +2°C

Material Specification

Body:	High tech polymer
Sight glass:	Polypropylene
Filter cover:	ABS
Adsorber element:	Activated carbon
Top & bottom endcap:	Glass filled nylon
Support cylinders:	Grade 430 stainless steel
Support media:	100% spun polypropylene
Support sock:	Polyester needlefelt
Encapsulant:	Epoxy resin / Hardener
Seals:	Nitrile NBR
Drain: Manual / Semi-auto	Acetal

Dimensions (mm)

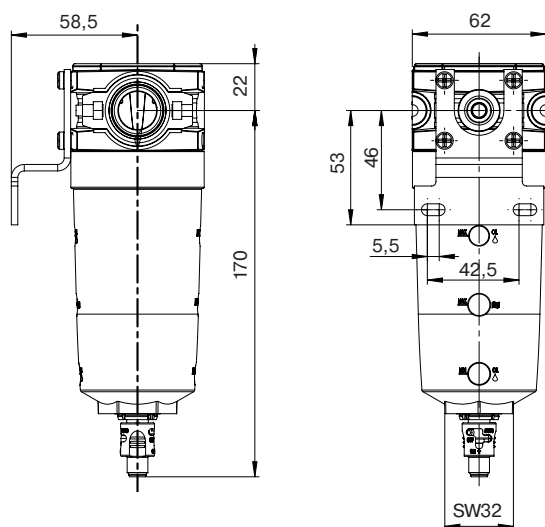

Service kits

Description	Order code
Adsorber element kit	P3XKA00ESA
Bowl kit with manual drain	P3XKA00BSC

Flow characteristics

(1/2) Adsorber Filter

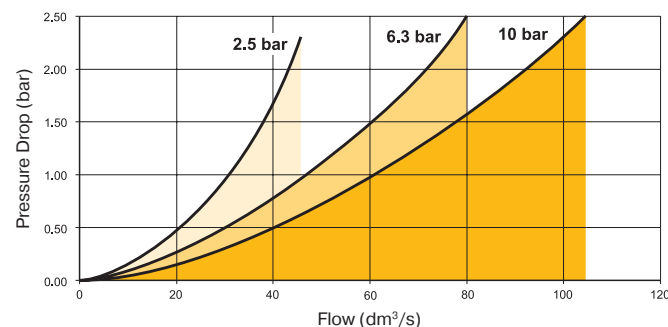

(3/4) Adsorber Filter

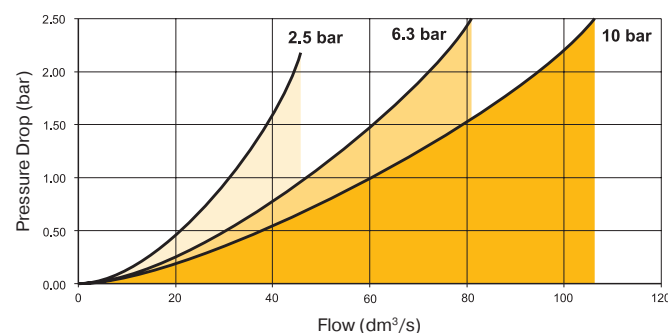

Regulators



Symbols

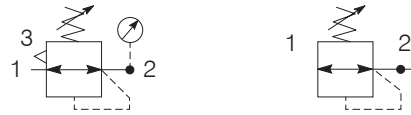

Self relieving regulator with gauge Non relieving regulator

- Integral 1/2 or 3/4 ports
- Secondary pressure ranges 8 & 16 bar
- Rolling diaphragm for extended life
- Secondary aspiration plus rolling diaphragm provides quick response and accurate pressure regulation.
- Optional tamperproof regulator, up to x 3 padlocks
- Relieving & Non-relieving types
- Low temperature -40°C as standard

Options:

P 3 X R A	1		B		N
BSPP (G)	1	1/2	B	Non rise - standard	0 - 4 bar No Gauge
NPT *		3/4		Tamperproof - Lockable	0 - 8 bar No Gauge
					0 - 16 bar No Gauge
					0 - 4 bar Gauge
					0 - 8 bar Gauge
					0 - 16 bar Gauge

* 1/2" NPT see Accessories

Port size	Description	Order Code	Flow dm ³ /s *	Max bar	Min temp °C	Max temp °C	Height mm	Width mm	Depth mm	Weight g
1/2	8 bar relieving	P3XRA14BNNN	122	16	-40	60	150	62	62	360
1/2	8 bar relieving + pressure gauge	P3XRA14BNGN	122	16	-10	60	150	62	95	410
3/4	8 bar relieving	P3XRA16BNNN	134	16	-40	60	150	62	62	360
3/4	8 bar relieving + pressure gauge	P3XRA16BNGN	134	16	-10	60	150	62	95	410
1/2	8 bar relieving with tamperproof facility	P3XRA14BANN	122	16	-40	60	158	62	62	360
1/2	8 bar relieving with tamperproof facility + pressure gauge	P3XRA14BAGN	122	16	-10	60	158	62	95	410
3/4	8 bar relieving with tamperproof facility	P3XRA16BANN	134	16	-40	60	158	62	62	360
3/4	8 bar relieving with tamperproof facility + pressure gauge	P3XRA16BAGN	134	16	-10	60	158	62	95	410

* flow with 10 bar inlet pressure, 6,3 bar set pressure and 1 bar pressure drop.
 Tamperproof regulator will require lock kit (on opposite page) to lock regulator.

Technical Information

Fluid:	Compressed air	
Maximum inlet pressure:	16 bar	
Temperature range*:	-40° to +60°C	
Typical flow with 10 bar inlet pressure, 6.3 bar set pressure and 1 bar pressure drop:	1/2"	122 dm ³ /s
	3/4"	134 dm ³ /s
Gauge port (x 2):	1/4"	

* Air supply must be dry enough to avoid ice formation at temperatures below +2°C

Material Specification

Body:	High tech polymer
Bonnet:	High tech polymer
Regulator cover:	ABS
Control Knob:	Polyamide
Valve:	Brass / Nitrile
Seals:	Nitrile NBR
Screws:	Stainless steel

Dimensions (mm)

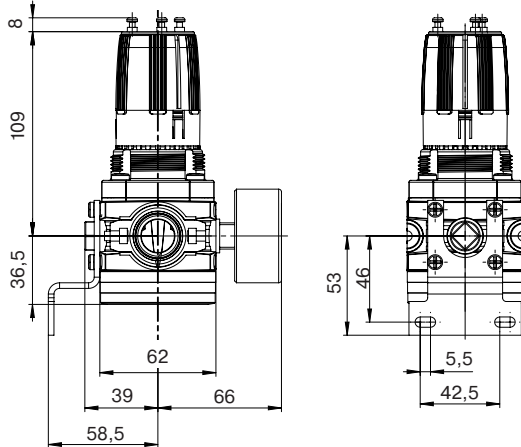

Service kits

Description	Order code
Wall bracket - Stainless steel	P3XKA00MW
Panel mounting nut	P3XKA00MM
Key lock	P3XKA00AS
Diaphragm kit (relieving type)	P3XKA00RR
Diaphragm kit (non-relieving type)	P3XKA00RN
Pressure Gauge 0 to 10 bar G1/4"	KG8012-00
0 to 16 bar G1/4"	KG8013-00

Lockable Tamperproof Kit (up to x 3 padlocks)

This facilitates the tamperproofing of the Regulator and Filter-Regulator units. (On request)



Order code

1 Padlock each	P3XKA00AS
----------------	------------------

Flow characteristics

Regulation characteristics: (1/2)

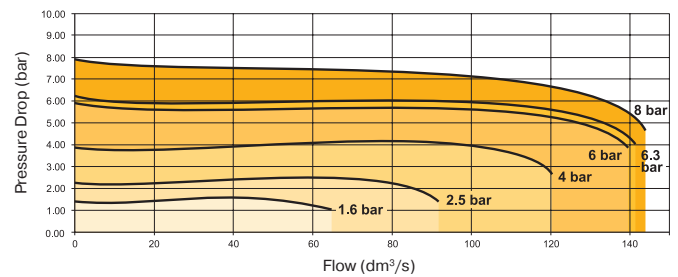

Regulation characteristics: (3/4)

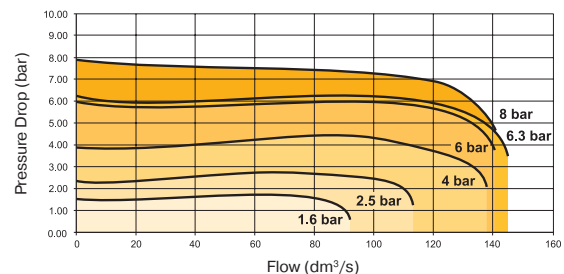

Filters / Regulators



Symbols

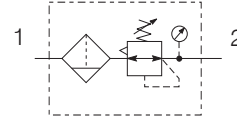

- Integral 1/2 or 3/4 ports
- High efficiency 5 micron element as standard
- Excellent water removal efficiency
- Secondary pressure ranges 8 and 16 bar
- Rolling diaphragm for extended life
- Secondary aspiration plus balanced poppet provides quick response and accurate pressure regulation.
- Low temperature -40°C with combined manual/semi - auto drain as standard

Options:

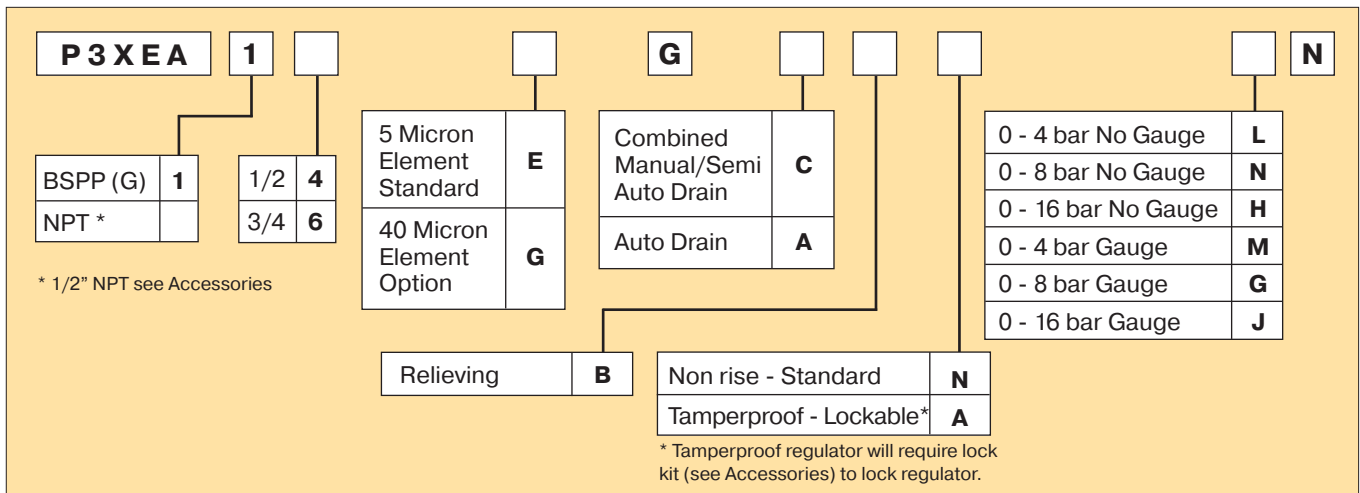

Port size	Description	Order Code	Flow dm ³ /s *	Max bar	Min temp °C	Max temp °C	Bowl capacity cm ³	Height mm	Width mm	Depth mm	Weight g
1/2	8 bar, relieving, Combined manual/semi auto drain	P3XEA14EGCBNNN	111	16	-40	60	60	280	62	62	500
1/2	8 bar relieving, auto drain	P3XEA14EGABNNN	111	16	-10	60	60	280	62	62	500
1/2	8 bar, relieving, gauge Combined manual/semi auto drain	P3XEA14EGCBNGN	111	16	-10	60	60	280	62	62	550
1/2	8 bar relieving, gauge, auto drain	P3XEA14EGABNGN	111	16	-10	60	60	280	62	62	550
3/4	8 bar, relieving, Combined manual/semi auto drain	P3XEA16EGCBNNN	113	16	-40	60	60	280	62	62	500
3/4	8 bar relieving, auto drain	P3XEA16EGABNNN	113	16	-10	60	60	280	62	62	500
3/4	8 bar, relieving, gauge Combined manual/semi auto drain	P3XEA16EGCBNGN	113	16	-10	60	60	280	62	62	550
3/4	8 bar relieving, gauge, auto drain	P3XEA16EGABNGN	113	16	-10	60	60	280	62	62	550

* flow with 10 bar inlet pressure, 6,3 bar set pressure and 1 bar pressure drop.

Technical Information

Fluid:	Compressed air
Maximum inlet pressure:	16 bar
Temperature range*:	
Auto drain:	-10° to +60°C
Combined drain:	-40° to +60°C
Particle removal:	5 micron and 40 micron
Typical flow with 10 bar inlet pressure 6,3 bar set pressure and 1 bar pressure drop	106 dm ³ /s
Manual / Semi-auto drain: pressure to close drain	0.8 bar
Auto drain: bowl pressure to close drain	0.8 bar
Operating range manual override facility	0.8 to 16 bar
Bowl sump capacity:	60 cm ³
Gauge ports (x 2):	1/4"

* Air supply must be dry enough to avoid ice formation at temperatures below +2°C

Dimensions (mm)

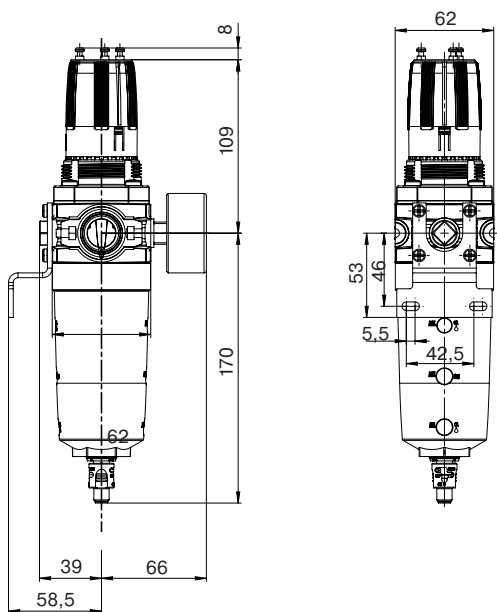

Service kits

Description	Order code
5 micron element kit	P3XKA00ESE
40 micron element kit	P3XKA00ESG
Bowl kit with combined manual/semi auto drain	P3XKA00BSC
Bowl kit with auto drain	P3XKA00BSA
Tamper-proof knob kit (keylock)	P3XKA00AS
Diaphragm kit (relieving type)	P3XKA00RR
Diaphragm kit (non-relieving type)	P3XKA00RN
Wall bracket kit - Stainless steel	P3XKA00MW
Panel mount nut	P3XKA00MM
Pressure Gauge 0 to 10 bar G1/4"	KG8012-00
0 to 16 bar G1/4"	KG8013-00
Key Lock	P3XKA00AS

Material Specification

Body:	High tech polymer
Sight glass:	Polypropylene
Body cover:	ABS
Element:	Sintered P.E.
Seals:	Nitrile NBR
Drains:	Manual / Semi-auto: Acetal
	Automatic: PA / Brass
Bonnet:	High tech polymer
Control knob:	Polyamide
Valve:	Brass / Nitrile
Screws:	Stainless steel

Flow characteristics

(1/2) 5 Micron Filter/Regulator

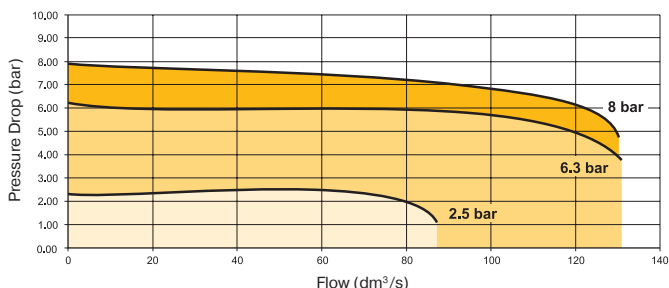

(3/4) 5 Micron Filter/Regulator

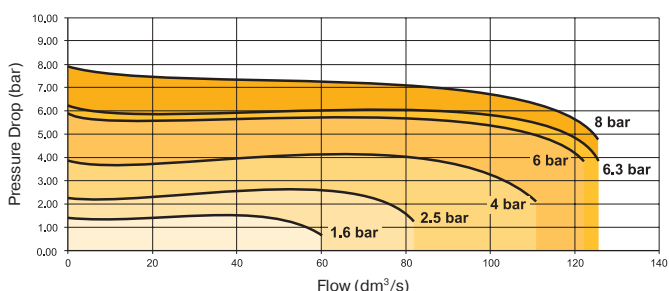

Lubricators



Symbols

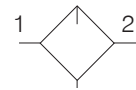

Lubricator

- Integral 1/2 or 3/4 ports
- Proportional oil delivery over a wide range of air flows.
- No adjustment necessary (self adjusting)
- Fill from top under system pressure

Options:

P3XLA	1			GNN										
<table border="1" style="margin: auto;"> <tr> <td style="padding: 2px;">BSPP (G)</td> <td style="padding: 2px; text-align: center;">1</td> </tr> <tr> <td style="padding: 2px;">NPT *</td> <td style="padding: 2px;"></td> </tr> </table>	BSPP (G)	1	NPT *		<table border="1" style="margin: auto;"> <tr> <td style="padding: 2px;">1/2</td> <td style="padding: 2px; text-align: center;">4</td> </tr> <tr> <td style="padding: 2px;">3/4</td> <td style="padding: 2px; text-align: center;">6</td> </tr> </table>	1/2	4	3/4	6	<table border="1" style="margin: auto;"> <tr> <td style="padding: 2px;">50 mg/m³</td> <td style="padding: 2px; text-align: center;">P¹⁾</td> </tr> </table>	50 mg/m ³	P ¹⁾		
BSPP (G)	1													
NPT *														
1/2	4													
3/4	6													
50 mg/m ³	P ¹⁾													
* 1/2" NPT see Accessories														

Port size	Description	Order Code	Flow dm ³ /s *	Max bar	Min temp °C	Max temp °C	Bowl capacity cm ³	Height mm	Width mm	Depth mm	Weight g
1/2	Oil mist, fill under pressure (50mg/m ³)	P3XLA14PGNN	78	16	-10	60	90	195	62	62	300
3/4	Oil mist, fill under pressure (50mg/m ³)	P3XLA16PGNN	78	16	-10	60	90	195	62	62	300

* Flow with 6,3 bar inlet pressure and 0,5 pressure drop.

¹⁾ Best for components which require effective lubrication (e.g. vane driven pneumatic motors / air tools etc.)

Technical Information

Fluid:	Compressed air
Maximum inlet pressure:	16 bar
Temperature range*:	-10° to +60°C

* Air supply must be dry enough to avoid ice formation at temperatures below +2° C
 Low flow start point (lubrication pick-up): at 6.3bar inlet pressure 7 dm³/s
 Typical flow with 6.3bar inlet pressure and 0.5 bar pressure drop: 78 dm³/s

Note : Fill lubricant from top only

Material Specification

Body:	High tech polymer
Bowl sight glass:	Polypropylene
Sight dome:	PA (Nylon)
Lubricator cover:	ABS
Seals:	Nitrile NBR

Dimensions (mm)

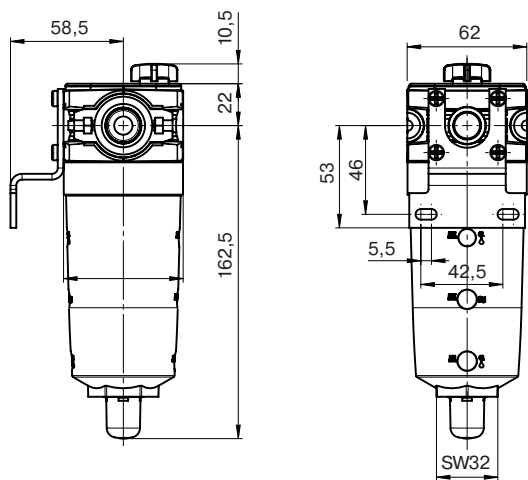

Flow characteristics

(1/2) Lubricator

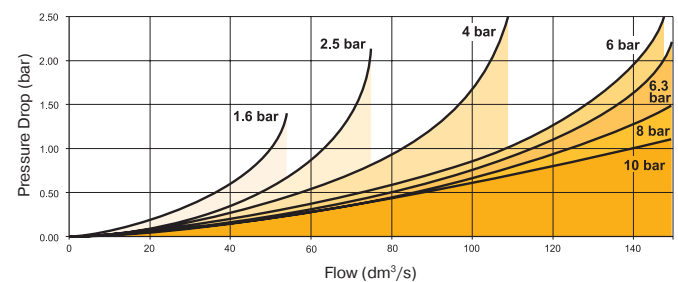

(3/4) Lubricator

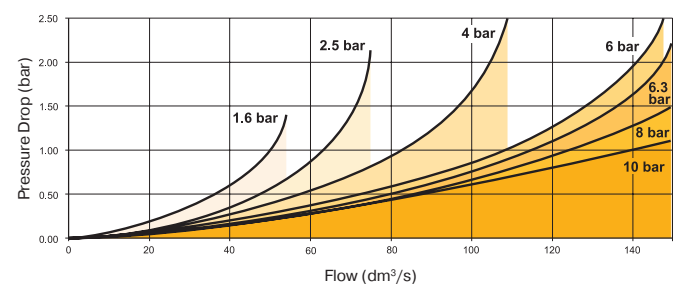

Service kits

Description	Order code
Bowl kit	P3XKA00BSN
Refill plug	P3XKA00PL
Oil VG15 - 100ml	P3XKA00PPA

**Soft Start/Dump Valves
Dump Valves**



Symbols

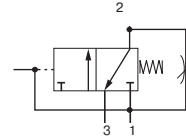

- Modular design with 1/2" & 3/4" integral ports (BSP or NPT)
- Provides for the safe introduction of pressure
- Automatically dumps downstream pressure on the loss of pilot signal
- Adjustable slow start
- Solenoid or air pilot options
- High flow & exhaust capability

P3X Series Combined Soft Start/Dump Valves, provide for the safe introduction of pressure to machines or systems. Soft Start/Dump Valves when set, allow the pressure to gradually build to the set point before fully opening to deliver full flow at line pressure.

The controlled introduction of pressure can be an important safety factor and prevent damage to tooling when air pressure is introduced at machine or system start up.

Options:

P3X	A	1	N	Solenoid type only	
Combined soft start dump valve	T	External air pilot	P	None (operator is fitted to valve)	O
Dump valve	D	Solenoid pilot	S	30 mm CNOMO coil (Form connection)	A
				22 mm coil (Form connection)	B
				Solenoid / coil not fitted	000
				24V DC	2CN
BSP (G)	1	1/2	4	30 mm operator	C
NPT *		3/4	6	Threaded air pilot	P

* 1/2" NPT see Accessories

Port size	Description	Order Code	Flow dm ³ /s	Max bar	Min temp °C	Max temp °C	Height mm	Width mm	Depth mm	Weight kg
1/2	Solenoid operated (not included)	P3XTA14SCN0000	80	16	-10	60	144	62	62	0.75
1/2	24VDC 22mm coil	P3XTA14SCNB2CN	80	10	-10	60	174	88	62	0.75
1/2	24VDC 30mm coil	P3XTA14SCNA2CN	80	16	-10	60	174	88	62	0.75
1/2	Air pilot operated	P3XTA14PPN	80	16	-10	60	127.5	62	62	0.75
3/4	Solenoid operated (not included)	P3XTA16SCN0000	88	16	-10	60	144	62	62	0.75
3/4	24VDC 22mm coil	P3XTA16SCNB2CN	88	10	-10	60	174	88	62	0.75
3/4	24VDC 30mm coil	P3XTA16SCNA2CN	88	16	-10	60	174	88	62	0.75
3/4	Air pilot operated	P3XTA16PPN	88	16	-10	60	127.5	62	62	0.75

Technical Information

Fluid:	Compressed air
Maximum pressure Solenoid operated 22mm coil:	10 bar
Maximum pressure Solenoid operated 30mm coil:	16 bar
Minimum operating pressure:	2 bar
Temperature range* Solenoid operated:	-10° to +60° C
Temperature range* Air Pilot operated:	-10° to +60° C
Air Pilot port:	1/8 BSP
Exhaust port:	1/2 BSP
Gauge port:	1/4 BSP
Typical flow with 6.3 bar inlet pressure and 1 bar pressure drop:	1/2" 80 dm ³ /s
	3/4" 80 dm ³ /s

* Air supply must be dry enough to avoid ice formation at temperatures below +2°C
 Snap pressure: Full flow when downstream pressure reaches 50% of the inlet pressure

Material Specification

Body:	Aluminium
Body cover:	ABS
Valve:	Brass / NBR composite
Pilot valve booster:	Aluminium
Seals:	Nitrile NBR

Solenoid coils

For Solenoid coil information refer to Solenoid Coils section.

Dimensions (mm)

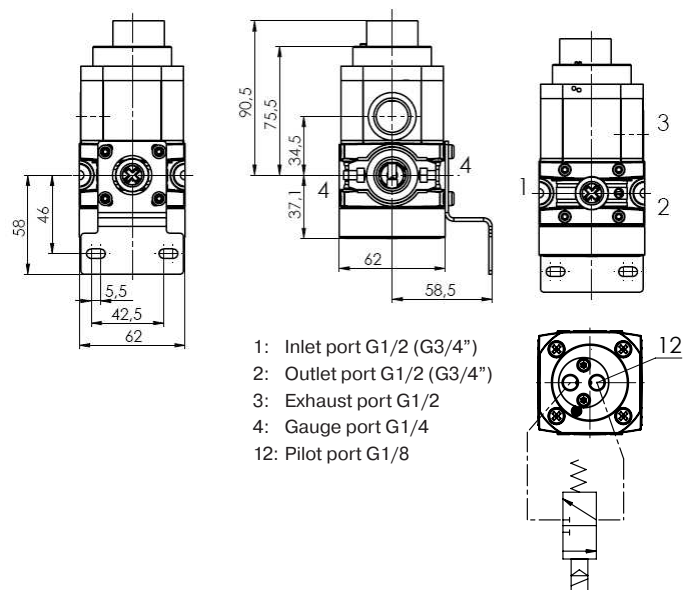
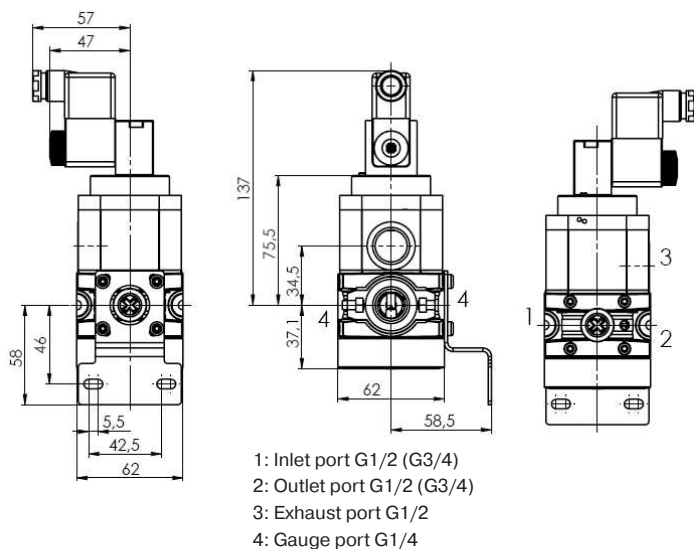

Flow characteristics

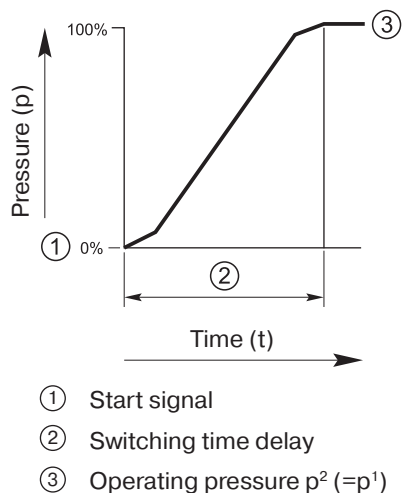

Soft Start Dump Valve 24v 1/2" Port

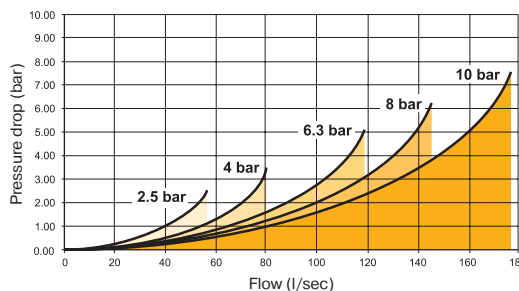

Slide Valves

Symbol

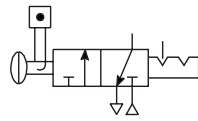

- Padlockable
- When the inlet pressure is turned off the downstream vents through the exhaust port

P3X Series Slide Valves provide shut off line pressure to prevent unauthorised adjustment.

Options:

P3X	VA	1		LSN
BSPP (G)	1	G1/2	4	
NPT *		G3/4	6	

* 1/2" NPT see Accessories

Technical Information

Operating Temperature:	-10° to +60°C
Maximum Supply Pressure:	16 bar
Weight (g):	G1/2" 300 g
	G3/4" 300 g

Material specification:

Body:	High tech polymer
Handle:	Polyamide
Seals:	Nitrile NBR
Exhaust muffler:	Sintered bronze

Dimensions (mm)

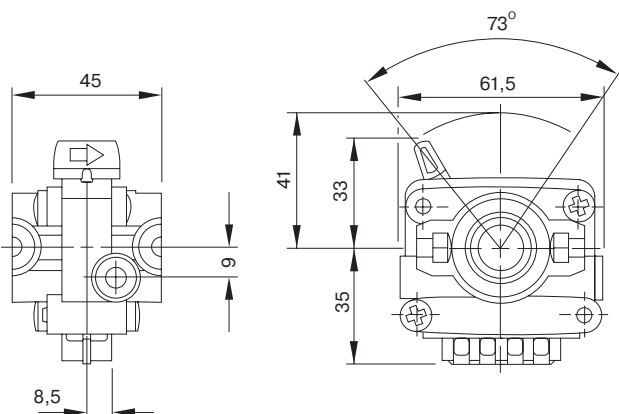

Manifolds



P3X Series Manifolds, provide up to 2 extra outlet ports, they may be assembled at any position in a combination e.g. before the lubricator to provide oil free take off or at the end of a combination to provide extra outlet ports.

Description	Order code BSPP	Weight (g)
G1/2"	P3XMA1V0N	170

Material specification:

Body:	High tech polymer
Manifold Cover:	ABS

Dimensions (mm)

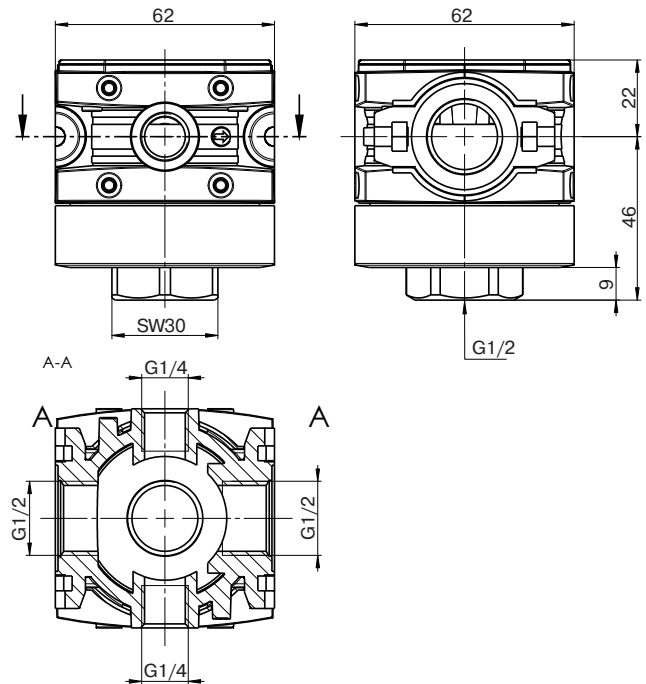

Inlet port	Bottom	Front and Back
1/2	1/2"	1/4"

Solenoid coils with Din A or Industrial B connection

Voltage	30 mm x 30 mm Order code DIN A Standard	Weight (Kg)	22 mm x 30 mm Order code Industrial B standard	Weight (Kg)
Direct current				
12V DC	P2FCA445	0.105	P2FCB445	0.093
24V DC	P2FCA449	0.105	P2FCB449	0.093
48V DC	P2FCA453*	0.105	P2FCB451	0.093
Alternative current				
12V 50/60Hz	P2FCA440	0.105	P2FCB440	0.093
24V 50/60Hz	P2FCA442	0.105	P2FCB442	0.093
48V 50/60Hz	P2FCA469#	0.105		
110V 50Hz, 120V 60Hz	P2FCA453	0.105	P2FCB453	0.093
230V 50Hz, 230V 60Hz	P2FCA457	0.105	P2FCB457	0.093



* P2FCA453 is compatible with 110 V AC and 48 V DC

P2FCA469 is 24 V DC 6.8W or 48 V 50Hz 9.9 VA

Solenoid coils with M12 connection

Voltage	Order code Form A 30 x 30	Weight (Kg)	Order code Form B 22 x 30	Weight (Kg)
Direct current				
24V DC	P2FC6419	0.065	P2FC7419	0.065

Accessories

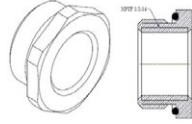
Description	Connection	Weight (g)	Order code	
Panel mounting nut		10	P3XKA00MM	
Stainless steel - Wall bracket kit		80	P3XKA00MW	
P3X connecting kit		10	P3XKA00CB	
Lubricator Oil	VG15 : ISO 3448 - 100ml	100	P3XKA00PPA	
Pressure gauge	0 to 10 bar 0 to 16 bar	1/4" 1/4"	KG8012-00 KG8013-00	
Connector O-ring kit	Qty: 5		P3XKA04CY	
Regulator & Filter/Regulator - Key Lock Kit		0.05	P3XKA00AS	
Kit to convert 3/4" BSP to 1/2" NPT air ports (2 O-Rings with 2 Adaptors). Body width 72 mm instead of 70 mm			P3XKA00CA	

Parker Hannifin Corporation
Motion Systems Group Europe
Parker Hannifin EMEA Sàrl European Headquarters
La Tuilière 6 Etoy
Switzerland CH-1163
www.parker.com

PDE2620TCUK 07/2024

Your Local Authorized Parker Distributor

© 2024 Parker Hannifin Corporation

